



New from Truth, The Button Lock! For years the standard of the industry has been Truth's EntryGard® and TrimLine™ Check Rail Locks - now, Truth has taken each of these products to a higher level, by incorporating a unique "button lock" feature.

**BUTTON LOCK:**

The advanced design of this special "button", located on the top of the lock, makes this feature easily accessible to the user. By simply pushing down on the button, the user releases the handle in both the open and closed positions. The handle will automatically lock back in place as it completes its travel - either fully opened, or as the cam becomes engaged with the keeper in the locked position. Besides its obvious security advantages, this new button feature prevents the cam from accidentally being rotated to the partially closed position which may result in unsightly marring of the top rail and muntin bars.

**SECURITY & RELIABILITY:**

The enhanced pick-resistant advantage created by the button lock feature, acts as a secondary security measure for this product. Specifically designed to ensure compliance with Canadian Forced Entry requirements, (under the tool manipulation specification), this new product has exceeded over 8,000 cycles in testing. The concealed locking mechanism helps protect moving parts from dust and dirt for added lock life.

**TIGHTER SEAL:**

The internal cam eliminates paint abrasions and produces a .125" (3.2 mm) pull-in with a .156" (4.0 mm) lifting ability. This action pulls the meeting rails tightly together and substantially reduces any air infiltration by producing a better seal of the sash at the head and sill. Styles are available with or without alignment lugs. These lugs help prevent shifting of the rails during locking for an enhanced window seal.

**IMPROVED HANDLE DESIGN:**

A new sleek & stylish handle has been created for both the EntryGard II and TrimLine versions of this lock. An improved detent in the handle motion is yet another performance

enhancement which assures the user that the cam is either fully open or closed.

**LOGO OPTIONS:** Have you ever considered personalizing your window? Truth's unique custom print logo reproduction process is easily adaptable to either the EntryGard II or TrimLine style locks. For further details on where your company's logo would appear, please refer to the enclosed drawings.

**WARRANTY:**

Protected under the terms of the Truth Warranty for Window & Door Manufacturers & Authorized Distributors. Refer to Truth's Terms & Conditions for further details.

**MATERIAL:** High pressure, corrosion resistant, die-cast zinc.

**FINISH:** Electrostatically applied, durable coatings that provide excellent resistance to chipping, scratching and corrosion while maintaining color stability for years in direct sunlight. Please refer to Truth's Color Chart for examples of Truth's most popular finish options. Truth also offers a wide range of decorative "plated" finishes - contact Truth for additional information on availability of these finishes on specific product lines.

**ORDERING INFORMATION:**

1. Choose the EntryGard II or TrimLine Lock style. Specify by part number.
2. Specify finish number.
3. Select mounting hardware (sold separately): For Keeper styles, refer to EntryGard® or TrimLine™ Keeper catalog pages for styles and part numbers.

**RECOMMENDED SCREWS:**

Types of screws required determined by material of profile used. Refer to drawings for complete information on screw type and quantity needed (sold separately). For additional information on screw selection - see Truth Tips.

**TRUTH TIPS:**

1. A lock with pick-resistant alignment lugs should be used whenever possible. A lock without lugs should be chosen when the lugs cause interference with divided light grills or other window features.



2. When two locks are used on one window, the placement of each lock, with respect to its keeper, becomes very critical to maintain a constant weatherseal on all sides of the window and to insure that each lock engages properly with its keeper.
3. For accurate hardware placement in vinyl or metal applications, pre-drilling of the window profile is recommended.
4. For vinyl window applications, mounting screws should pass through two PVC walls, or one PVC wall and one insert wall. For this reason, it may be necessary to use a longer screw than is recommended.
5. For metal window profiles, Truth recommends stainless steel machine screws. However, in most applications, stainless steel sheet metal screws will provide adequate holding power.

**INCLUDE TRUTH SPECS ON YOUR NEXT WINDOW PROJECT**

Window check rail locks shall be included which will increase both security and weather seal tightness. The lock must provide easy operation, positive locked feel (detent) and top mounted locking button. The locking button will increase tamper resistance for meeting Canadian Forced Entry standards.

Window check rail locks will be of internal cam design to provide .125" (3.2 mm) of pull-in to aid in sealing the meeting rails. The lock and accompanying keeper will prevent misalignment during locking. The lock and keeper shall be constructed of high pressure zinc alloy die castings.

Window locks shall be 17 series EntryGard, or TrimLine style Button Locks as manufactured by Truth

FIG. 1 APPLICATION OF TRUTH TRIMLINE BUTTON LOCK

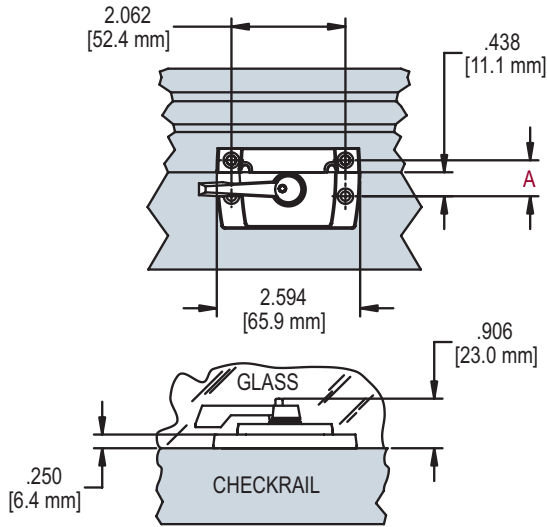

NOTE:

1. CAM HAS .125 PULL - IN.
2. REFER TO TRIMLINE KEEPER CATALOG SECTION FOR KEEPERS AND DETAILS ON OR DIMENSIONS
3. REFER TO TRIMLINE LOCK CATALOG FOR AVAILABLE LOGO AREAS

**RECOMMENDED SCREWS:**

WOOD: (QTY 2)-(P/N 19050) #6 X .750 PHILLIPS, FLAT HEAD, SHEET METAL SCREWS

PVC/METAL: (QTY 2)-#6 PHILLIPS, FLAT HEAD SCREWS (LENGTH AND THREAD TO BE DETERMINED BY PROFILE)

PRODUCT NUMBER	COMMENTS
17.65	SIMILAR TO 17.32

FIG. 2 APPLICATION OF TRUTH ENTRYGARD\* II BUTTON LOCK

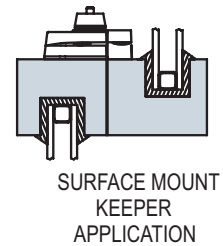
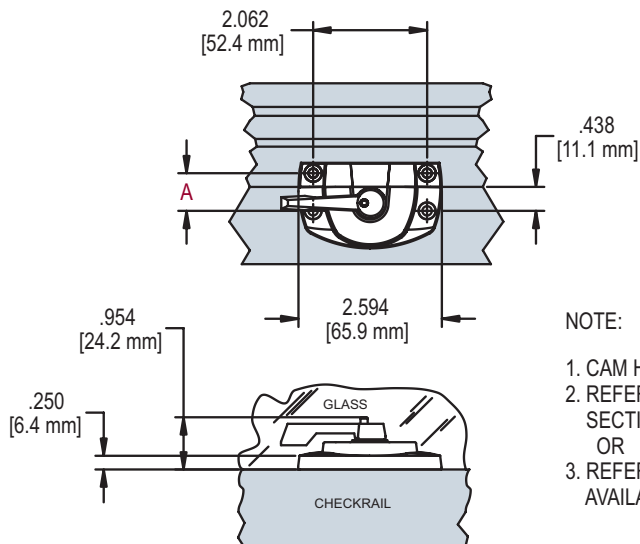

NOTE:

1. CAM HAS .125 PULL - IN.
2. REFER TO TRIMLINE KEEPER CATALOG SECTION FOR KEEPERS AND DETAILS ON OR DIMENSIONS
3. REFER TO TRIMLINE LOCK CATALOG FOR AVAILABLE LOGO AREAS

**RECOMMENDED SCREWS:**

WOOD: (QTY 2)-(P/N 19110) #7 X .750 PHILLIPS, FLAT HEAD, SHEET METAL SCREWS

PVC/METAL: (QTY 2)-#7 PHILLIPS, FLAT HEAD SCREWS (LENGTH AND THREAD TO BE DETERMINED BY PROFILE)

PRODUCT NUMBER	WITH LUGS	WITHOUT LUGS	COMMENTS
17.66		X	SIMILAR TO 17.23
17.69	X		SIMILAR TO 17.19