



One of the most popular locking designs in the slider and single/double-hung markets, Truth Hardware's 9400 Series Sash Lock is one of the most reliable products available.

- Concealed locking mechanisms help protect moving parts from dust and dirt for added lock life while producing a better seal of the sash at the head and sill.
- The internal cam eliminates unsightly paint abrasions caused by the interaction of cam and keeper.
- The internal cam's are "handed" and come in various sizes that relate to the amount of pull-in/reach-out and sash lift. These "lock-up" characteristics produce a better seal of the sash at the head and sill to help decrease air infiltration.
- The location of the mounting holes on the base are designed to secure the lock in a position along the check rail which affords the most holding power (See Truth Tip #4).
- These locks are available with or without alignment lugs. These lugs have been designed to help prevent shifting of the rails during locking for an enhanced window seal. Tapered "nesting" lugs, which help guide the lock to the keeper are also an option.

**WARRANTY:**

Protected under the terms of the "Truth Warranty for Window & Door Manufacturers & Authorized Distributors". Refer to Truth's Terms & Conditions for further details.

**LOGO OPTIONS:** For that "personalized touch", Truth's 9400 Series Sash Locks are capable of accepting your company's name or logo. Truth's logo reproduction processes is an attractive way of highlighting your company signature.

**MATERIAL:** High-pressure, corrosion resistant, die-cast zinc.

**FINISH:** Electrostatically applied, durable coatings that provide excellent resistance to chipping, scratching and corrosion while maintaining color stability for years in direct sunlight.



Please refer to Truth's Color Chart for examples of Truth's most popular finish options. Truth also offers a wide range of decorative "plated" finishes – contact Truth for additional information on availability of these finishes on specific product lines.

**ORDERING INFORMATION:**

1. Identify the style of "base" desired (specify by part number).
2. Identify the style of "cam" desired. Note these cams are "handed" (specify by part number).
3. Order the 9400 Series assembled base unit that has this configuration. Truth Hardware Sales Team can help you identify this part number.
4. Order the 9400 Series style of "keeper" desired (specify by part number).
5. Specify finish choice.

**RECOMMENDED SCREWS:**

Types of screws required determined by material of profile used (sold separately). For additional information on screw selection – see Truth Tips.

**TRUTH TIPS:**

1. A lock with pick-resistant alignment lugs should be used whenever possible. A lock without lugs should be chosen when the lugs cause interference with divided light grills or other window features.
2. When two locks are used on one window, the placement of each lock, with respect to its keeper, becomes very critical to maintain a constant weatherseal on all sides of the window and to insure that each lock engages properly with its keeper.

3. For accurate hardware placement in vinyl or metal applications, pre-drilling of the window profile is recommended.

4. For vinyl window applications, mounting screws should pass through two PVC walls, or one PVC wall and one insert wall. For this reason, it may be necessary to use a longer screw than is recommended.

5. For metal window profiles, Truth recommends stainless steel machine screws. However, in most applications, stainless steel sheet metal screws will provide adequate holding power.

**INCLUDE TRUTH SPECS ON YOUR NEXT WINDOW PROJECT**

Window check rail locks shall be included which will increase both security and weather seal tightness. The lock must provide easy operation and positive locked feel.

Window check rail locks will be of internal cam design to provide optimum sealing of the meeting rails. The lock and accompanying keeper will prevent misalignment during locking. The lock and keeper shall be constructed of high pressure zinc alloy die castings.

Window locks shall be 9400 Series Sash Locks as manufactured by Truth Hardware.

FIG. 1 SASH LOCK AND KEEPER

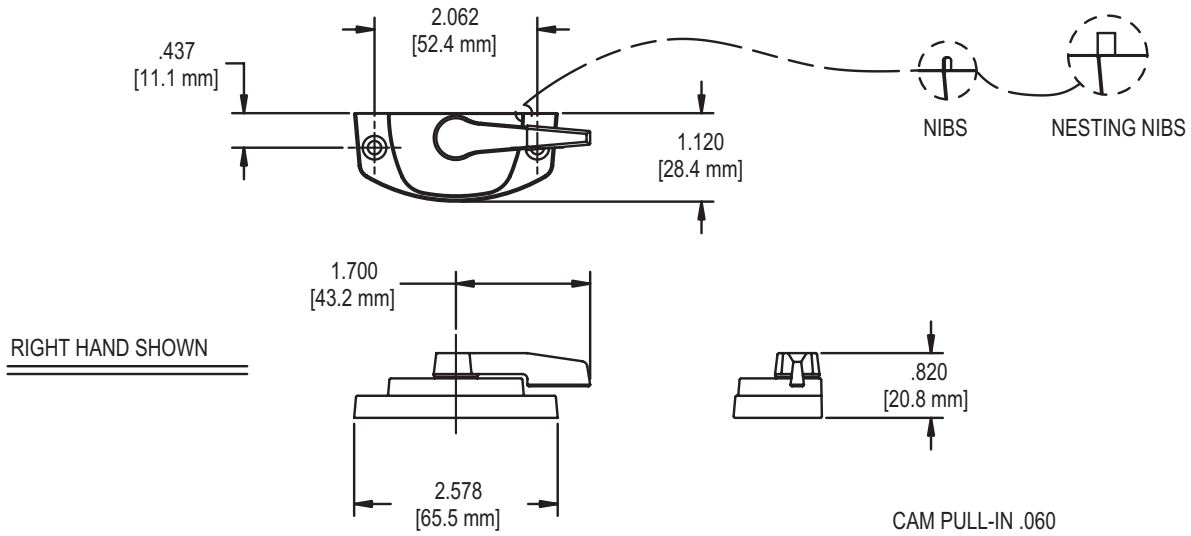

PART NUMBER	HANDING		NIBS		
	RH	LH	NO NIBS	NIBS	NESTING NIBS
A09400400	X		X		
A09400401	X			X	
A09400444	X				X

RECOMMENDED SCREWS:

WOOD: (QTY 2) (P/N 19050) #6 X .750  
PHILLIPS FLAT HEAD SHEET METAL  
SCREWS

PVC/METAL: (QTY 2) #6 PHILLIPS FLAT HEAD  
SCREW (LENGTH AND THREAD TYPE  
TO BE DETERMINED BY PROFILE)

FIG. 2 C09405.XX KEEPER

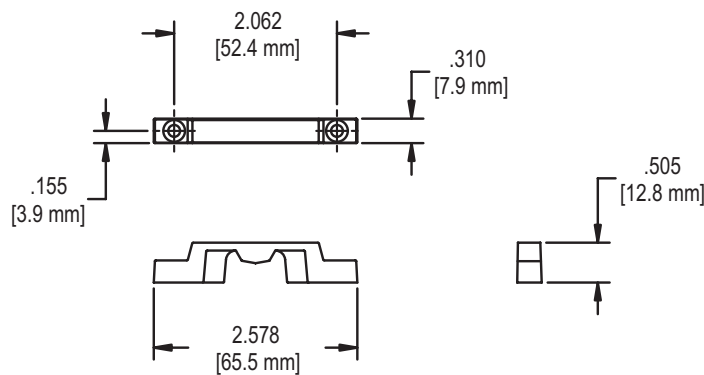

RECOMMENDED SCREWS:

WOOD: (QTY 2) (P/N 19050) #6 X .750  
PHILLIPS FLAT HEAD SHEET METAL  
SCREWS

PVC/METAL: (QTY 2) #6 PHILLIPS FLAT HEAD  
SCREW (LENGTH AND THREAD TYPE  
TO BE DETERMINED BY PROFILE)

AVAILABLE LOCKS
A09400400

FIG. 3 C09603XX KEEPER

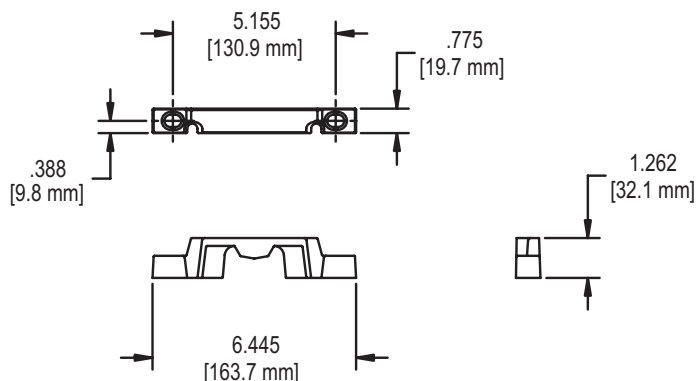

RECOMMENDED SCREWS:

WOOD: (QTY 2) (P/N 19050) #6 X .750  
PHILLIPS FLAT HEAD SHEET METAL  
SCREWS

PVC/METAL: (QTY 2) #6 PHILLIPS FLAT HEAD  
SCREW (LENGTH AND THREAD TYPE  
TO BE DETERMINED BY PROFILE)

AVAILABLE LOCKS
A09400401

FIG. 4 C030063XX KEEPER

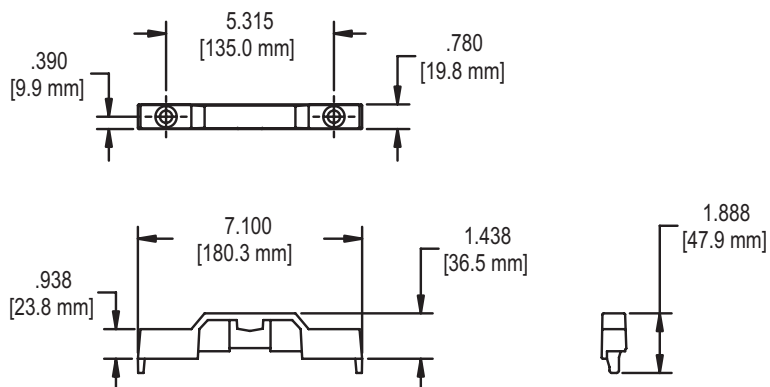

RECOMMENDED SCREWS:

WOOD: (QTY 2) (P/N 19050) #6 X .750  
PHILLIPS FLAT HEAD SHEET METAL

PVC/METAL: (QTY 2) #6 PHILLIPS FLAT HEAD  
SCREW (LENGTH AND THREAD TYPE  
TO BE DETERMINED BY PROFILE)

AVAILABLE LOCKS
A09400444

