



Truth Hardware's new 700 Series Locks are by far the most exciting aesthetic changes that have hit the checkrail marketplace in years. There are four new designs within the 700 Series family of locks - each with its own distinct appearance. However, as unique as they each are to the eye, the similarities in quality features that the 700 Series have as a whole make these products the "first family" of check rail locks.

FORGIVING CAM:

The forgiving cam is likely the most valuable feature that the window manufacturers will realize. This patented new innovative design helps to insure proper engagement between the lock and keeper even on assemblies where these two components may be misaligned. The benefits of this forgiving cam can help to reduce field service calls down the road.

SECURITY & RELIABILITY:

The pick-resistant design of these locks helps you exceed forced entry requirements.

POSITIVE SECURE ACTION:

An improved detent in both the locking and unlocking motion of the handle, assures the homeowner that the cam has completed its travel.

TIGHTER SEAL:

By pulling meeting rails tightly together and by producing a better seal of the sash at the head and sill, the 700 Series Lock decreases air infiltration. These locks produce a .105" (2.7mm) lifting ability (Arc style lock has a .156" (4.0mm) lifting ability). And with their new slimmer handle design options, their low profile design helps assure maximum egress opening. An innovative spring design holds the handle in both the locked and unlocked positions while a concealed locking mechanism protects moving parts from dust and dirt for added lock life.

INTERCHANGEABLE:

Designed for 2.062" (52.4mm) center-to-center hole spacing on both the lock and keepers, the 700 Series Locks are interchangeable with existing designs making the move up to this new design virtually seamless.

LOGO OPTIONS:

For that "personalized touch", most of Truth's 700 Series Check Rail Locks are capable of accepting your company's name or logo. Truth's unique custom print logo reproduction process is an attractive way of highlighting your company signature. For further details on the locks that accept this process, and where your company's logo would appear, please refer to the following drawings.

WARRANTY:

Protected under the terms of the Truth Warranty for Window & Door Manufacturers and Authorized Distributors. Refer to Truth's Terms & Conditions for further details.

MATERIAL:

High-pressure, corrosion-resistant, die-cast zinc.

FINISH:

Electrostatically applied, durable coatings that provide excellent resistance to chipping, scratching and corrosion while maintaining color stability for years in direct sunlight. Please refer to Truth's Color Chart for examples of Truth's most popular finish options. Truth also offers a wide range of decorative "plated" finishes - contact Truth for additional information on availability of these finishes on specific product lines.

ORDERING INFORMATION:

1. Choose the 700 Series Lock style desired (specify by part number).
2. Order the appropriate Keeper to fit your lock and window profile (refer to drawings).
3. Specify finish number.
4. Select screws (fasteners). Sold separately.

RECOMMENDED SCREWS:

4 - Phillips Flat Head Sheet Metal Screws. Refer to lock and keeper drawings for additional specs. (Length and thread type to be determined by profile) For further information on screw selection - see Truth Tips.



LOW S LOCK



ARC LOCK



DELTA LP1 LOCK



DELTA LP2 LOCK

700 SERIES LOCKS

TRUTH TIPS:

1. When two locks are used on one window, the placement of each lock, with respect to its keeper, becomes very critical to maintain a constant weatherseal on all sides of the window and to insure that each lock engages properly with its keeper.
2. For accurate hardware placement in vinyl or metal applications, pre-drilling of the window profile is recommended.
3. For vinyl window applications, mounting screws should pass through two PVC walls, or one PVC wall and one insert wall. For this reason, it may

be necessary to use a longer screw than is recommended.

4. For metal window profiles, Truth recommends stainless steel machine screws. However, in most applications, stainless steel sheet metal screws will provide adequate holding power.

INCLUDE TRUTH SPECS ON YOUR NEXT WINDOW PROJECT

Window check rail locks shall be included which will increase both security and weather seal tightness. The lock must provide easy operation and positive locked feel (detent).

Window check rail locks will be of internal cam design to provide .062" (4.0 mm) of pull-in to aid in sealing the meeting rails. The lock and accompanying keeper will help insure proper engagement even on assemblies where these two components may be misaligned. The lock and keeper shall be constructed of high pressure zinc alloy die castings.

Window locks shall be 700 Series Locks, as manufactured by Truth Hardware.

FIG. 1 APPLICATION OF 700 SERIES CHECKRAIL LOCKS

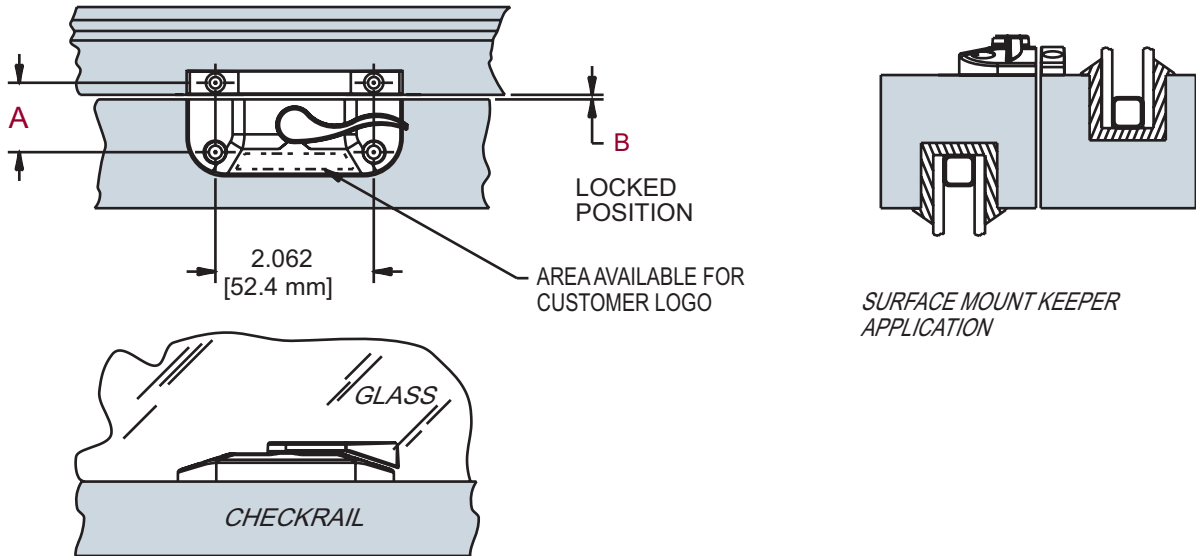
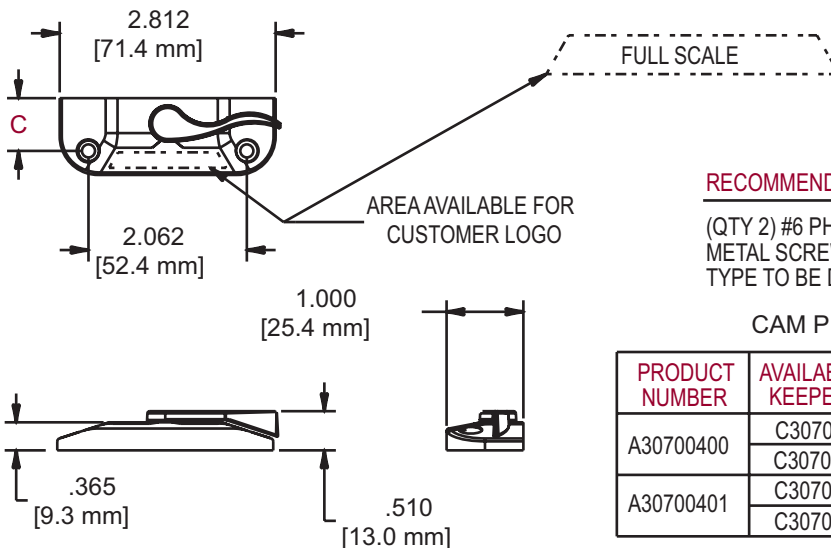

FIG. 2 700 SERIES LOW S LOCK



RECOMMENDED SCREWS:

(QTY 2) #6 PHILLIPS FLAT HEAD SHEET METAL SCREW.(LENGTH AND THREAD TYPE TO BE DETERMINED BY PROFILE.)

CAM PULL-IN: .117 [2.9mm]

PRODUCT NUMBER	AVAILABLE KEEPERS	A	B	C
A30700400	C30705	.903 [22.9mm]	.060 [1.5mm]	.687 [17.4mm]
	C30706	.888 [22.5mm]		.437 [11.1mm]
A30700401	C30705	.653 [16.6mm]	.060 [1.5mm]	.437 [11.1mm]
	C30706	.638 [16.2mm]		.437 [11.1mm]

FIG. 3 700 SERIES ARC LOCK

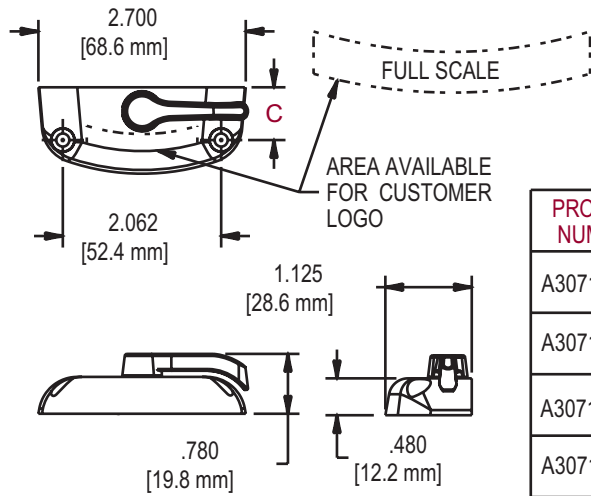

RECOMMENDED SCREWS:
 (QTY 2) #7 PHILLIPS FLAT
 head SHEET METAL SCREWS.
 (LENGTH AND THREAD TYPE
 TO BE DETERMINED BY PROFILE.)

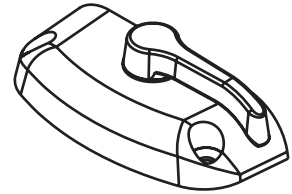

PRODUCT NUMBER	AVAILABLE KEEPERS	CAM PULL-IN	A	B	C
A30710400	C30715	.070 [1.7mm]	.903 [22.9mm]	.060 [1.5mm]	.687 [17.4mm]
	C30716		.882 [22.4mm]		.437 [11.1mm]
A30710401	C30715		.653 [16.6mm]	.030 [.7mm]	.687 [17.4mm]
	C30716		.632 [16.1mm]		.437 [11.1mm]
A30710402	C30715	.100 [2.5mm]	.873 [22.1mm]	.030 [.7mm]	.687 [17.4mm]
	C30716		.852 [21.6mm]		.437 [11.1mm]
A30710403	C30715		.623 [15.8mm]	.060 [1.5mm]	.687 [17.4mm]
	C30716		.602 [15.2mm]		.437 [11.1mm]

FIG. 4 700 SERIES DELTA LP1 LOCK

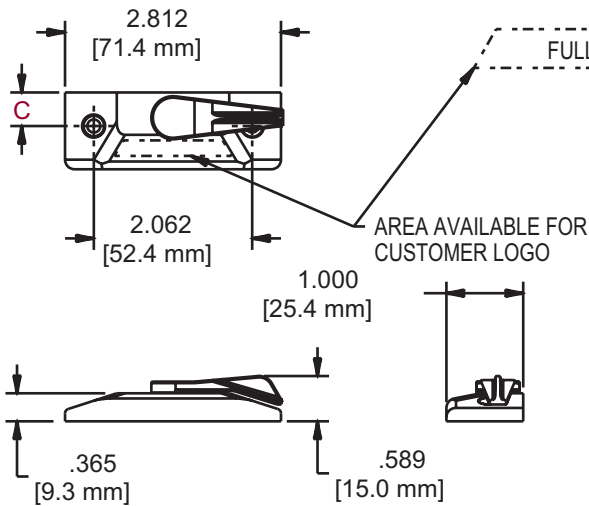

RECOMMENDED SCREWS:
 (QTY 2) #6 PHILLIPS FLAT
 HEAD SHEET METAL SCREWS.
 (LENGTH AND THREAD TYPE
 TO BE DETERMINED BY PROFILE.)

CAM PULL-IN: .117 [2.9mm]

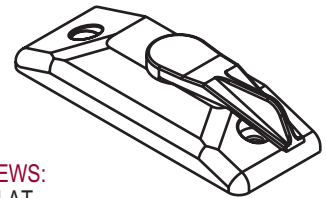

PRODUCT NUMBER	AVAILABLE KEEPERS	A	B	C
A30730400	C30705	.903 [22.9mm]	.060 [1.5mm]	.687 [17.4mm]
	C30706	.888 [22.5mm]		.437 [11.1mm]
A30730401	C30705	.653 [16.6mm]	.060 [1.5mm]	.687 [17.4mm]
	C30706	.638 [16.2mm]		.437 [11.1mm]

FIG. 5 700 SERIES DELTA LP2 LOCK

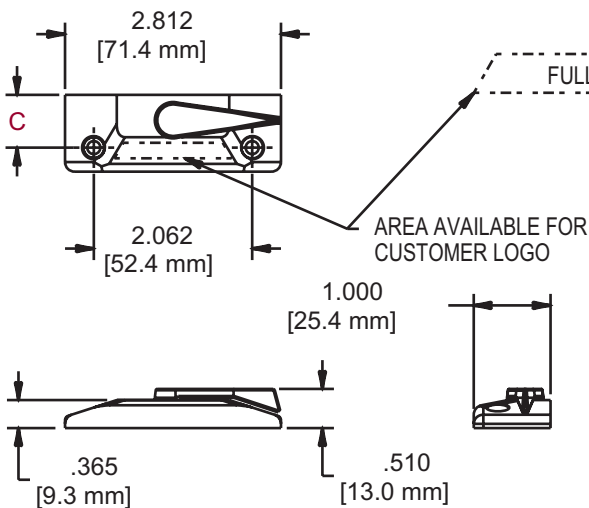

RECOMMENDED SCREWS:
 (QTY 2) #6 PHILLIPS FLAT
 HEAD SHEET METAL SCREWS.
 (LENGTH AND THREAD TYPE
 TO BE DETERMINED BY PROFILE.)

CAM PULL-IN: .117 [2.9mm]

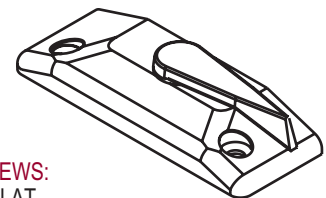

PRODUCT NUMBER	AVAILABLE KEEPERS	A	B	C
A30720400	C30705	.903 [22.9mm]	.060 [1.5mm]	.687 [17.4mm]
	C30706	.888 [22.5mm]		.437 [11.1mm]
A30720401	C30705	.653 [16.6mm]	.060 [1.5mm]	.687 [17.4mm]
	C30706	.638 [16.2mm]		.437 [11.1mm]

FIG. 6 C 30705 CHECK RAIL LOCK KEEPER

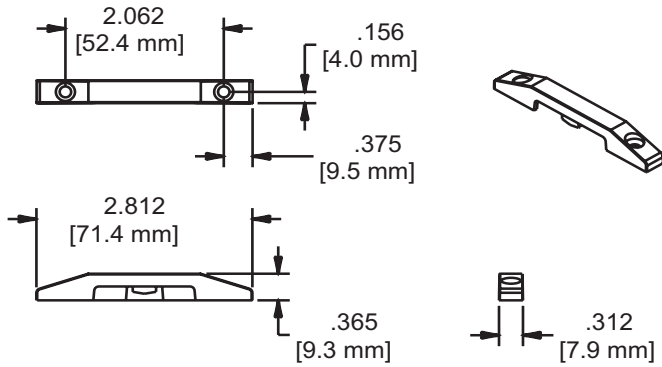

AVAILABLE LOCKS	A	B
A30700400	.903 [22.9mm]	.060 [1.5mm]
A30700401	.653 [16.6mm]	
A30720400	.903 [22.9mm]	
A30720401	.653 [16.6mm]	
A30730400	.903 [22.9mm]	
A30730401	.653 [16.6mm]	

RECOMMENDED SCREWS:
 (QTY 2) #6 SCREW WITH A #5 HEAD, PHILLIPS FLAT HEAD SHEET METAL SCREW. (LENGTH AND THREAD TYPE TO BE DETERMINED BY PROFILE.)

FIG. 7 C 30706 CHECK RAIL LOCK KEEPER

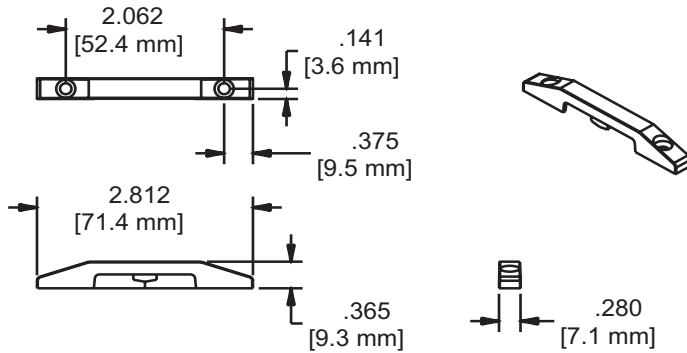

AVAILABLE LOCKS	A	B
A30700400	.888 [22.5mm]	.060 [1.5mm]
A30700401	.638 [16.2mm]	
A30720400	.888 [22.5mm]	
A30720401	.638 [16.2mm]	
A30730400	.888 [22.5mm]	
A30730401	.638 [16.2mm]	

RECOMMENDED SCREWS:
 (QTY 2) #6 SCREW WITH A #5 HEAD, PHILLIPS FLAT HEAD SHEET METAL SCREW. (LENGTH AND THREAD TYPE TO BE DETERMINED BY PROFILE.)

FIG. 8 C 30715 CHECK RAIL LOCK KEEPER

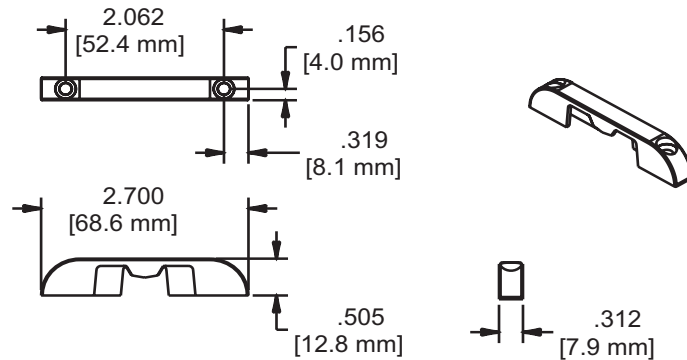

AVAILABLE LOCKS	A	B
A30710400	.903 [22.9mm]	.060 [1.5mm]
A30710401	.653 [16.6mm]	
A30710402	.873 [22.1mm]	.030 [.7mm]
A30710403	.623 [15.8mm]	

RECOMMENDED SCREWS:
 (QTY 2) #6 PHILLIPS FLAT HEAD SHEET METAL SCREW. (LENGTH AND THREAD TYPE TO BE DETERMINED BY PROFILE.)

FIG. 9 C 30716 CHECK RAIL LOCK KEEPER

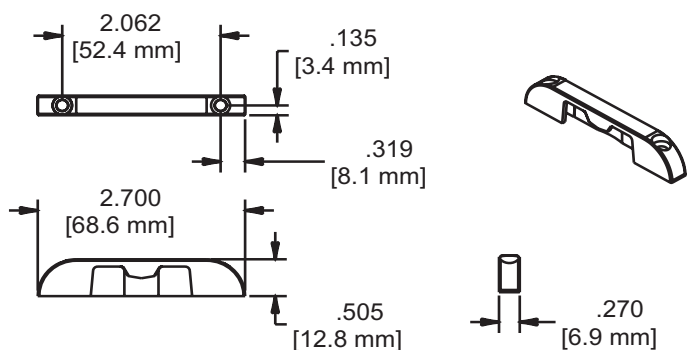

AVAILABLE LOCKS	A	B
A30710400	.882 [22.4mm]	.060 [1.5mm]
A30710401	.632 [16.1mm]	
A30710402	.852 [22.6mm]	.030 [.7mm]
A30710403	.602 [15.2mm]	

RECOMMENDED SCREWS:
 (QTY 2) #6 SCREW WITH A #5 HEAD, PHILLIPS FLAT HEAD SHEET METAL SCREW. (LENGTH AND THREAD TYPE TO BE DETERMINED BY PROFILE.)